

**METHOD STATEMENT
FOR
PIPE WELDING WORKS**

Introduction

This Method statement describes in detail the welding process for pipe work and the welder's qualification test procedures. This includes addressing programs for implementing commitments regarding the quality of welding works.

Contents

- 1.0 Scope and Purpose of Method Statement
- 2.0 Index
- 3.0 Description of Activities
- 4.0 List of Main Equipment
- 5.0 Health, Safety and Environment Measures

1.0 Scope and Purpose of Method Statement

This document outlines the method for executing welding process for pipe work and welding procedure qualification test for welders. This method statement covers all piping welding works for Burj Dubai Tower Project either shop fabricated or site installed.

The procedure provides guidance for assessing the activities for jointing mechanical piping system. This guidance is based on the requirements set forth in the Safety Requirement Document (SRD) and The Quality Assurance Program (QAP).

1.1 Objectives

This document provides guidance in implementing an effective program for all pipe welding works. This includes addressing programs for the following: (1) implementing commitments regarding the quality of the weld joints; (2) managing and providing oversight to ensure installation and related quality control have been adequately addressed by specifications, drawings, and procedures; (3) managing and providing supervision and control to assure qualification of welders; and (4) recording installation and test activities.

This procedure is one component of a complete construction and inspection program. This and other procedures will be used, as needed, to provide assurance that construction activities are being conducted as required by the specification and manufacturer procedures. It is not expected that completion of the entire procedure will be accomplished during any one inspection and/or every time the inspection procedure is used. It is a continuing activity until all piping networks are installed and tested.

1.2 Inspection and Recording Requirements

The engineer should verify that the supervisor/foreman with construction responsibilities for the pipe welding works is familiar with this method statement and is issued with copies of the inspection checklists and test plans.

The engineer should satisfy procedures provided by QA/QC inspections to ensure the pipe welding works meet specified engineering requirements and drawings. As part of the assessment, the QC Inspection Procedures, must ensure a quantitative or qualitative acceptance criteria for determining the prescribed activities have been accomplished satisfactorily.

The QC inspection personnel, in coordination with Site Supervisor, should verify that the quality of the pipe welding works and related testing activities are within the project design specifications requirements.

The Supervisor should verify that the pipe welding works is accomplished in accordance with the specifications and the manufacturer's procedures.

The Supervisor should verify any as-built record of pipe welding works and testing, and confirm that the information meets the project requirements.

1.3 Inspection Guidance

Pipe welding works need to follow strictly established codes and safety procedures.

Care should be taken to ensure that applicable codes and standards be strictly adhered to during pipe welding works.

The Supervisor can choose to follow the most appropriate welding technique applicable at such a given time and in coordination with the construction progress, QA/QC inspection and testing requirements. The Engineers should use judgment in determining sample selection focusing on examination of the most important aspects of the particular welding activity being inspected. The intent is to establish a high level of assurance that the end product meets the project requirements.

Review the implementing procedures and safety standards for the pipe welding works provided by the QA/QC. The QA/QC inspectors should verify that the procedures (1) are approved, and (2) specify the requirements of the design and/or from the manufacture's technical manual(s) and codes or standards prescribed by the Client.

1.4 Training and Qualification of Personnel

The Supervisor should verify that the personnel have sufficient knowledge of the procedure requirements. The Supervisor should review any training and qualification

records for those individuals who shall do the task to determine whether they are skilled enough to follow the procedure before the actual work is carried out.

2.0 Index

2.1 Preparation of Materials and Execution of Works

- General
- Pipe Joint Preparation
- Pipe to Pipe Fit Up
- 45° Elbow to Pipe Fit Up
- 90° Elbow to Pipe Fit Up
- Tee to Pipe Fit Up
- Flange to Pipe Fit Up

2.2 Welding Procedure Qualification Test Requirements

- Welding Process
- Base Metals
- Filler Metals
- Position of Groove & Weld Progression
- Temperature Requirements
- Postweld Heat Treatment
- Type of Gas
- Electrical Characteristics
- Travel Speed & Passes
- Laboratory Test Results

3.0 Description of Activities

3.1 General

- Check all pipes and fittings to be used for joint are free from defects, dents or deformities and are straight. Remove pipes and fittings with defects and replace with acceptable materials.
- Remove foreign matter or dirt from inside of the pipe and fittings before fit up.
- For longer work breaks, place suitable stoppers to prevent debris, earth or water from entering pipe open ends.
- Welding electrodes shall be stored and handled as per Manufacturer's instructions.

3.2 Pipe Joint Preparation

- Cut the pipes to the required length using an appropriate pipe cutter, or profile cutter (Oxy-Acetylene), allowing for provision of pipe fitting later. Works shall be carried out in accordance with the approved shop drawings.
- The pipes shall be checked by the assigned foreman for its squareness and straightness, after being cut to the correct angle and site requirements, as per sample of welding details in Figure 1 shown below.

PARENT METAL SPECIFICATION.	: API 5L Gr B and Equiv.
QUALIFICATION CODE/STANDARD.	: ANSI B31.1 / ASME Sec IX(1st July'2001 Edition)
PIPE MATERIAL THICKNESS(mm).	: 7.1mm (Standard Wall)
PIPE DIAMETER(mm)	: 6 Inch NPS
WELDING PROCESS.	: SMAW
JOINT TYPE.	: SINGLE "V", FULL PENETRATION PIPE BUTT JOINT & FILLET WELDS(SINGLE & MULTIPASS)
POSITION.	: 6G (All POSITIONS)

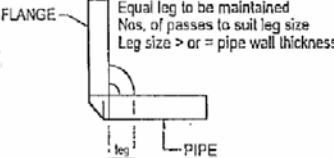
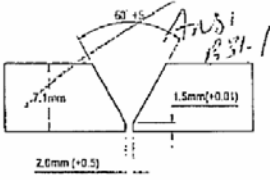
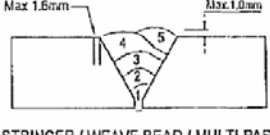
FILLET WELDS	GROOVE JOINT DESIGN	WELDING SEQUENCE
		

PROCEDURE DETAILS								
RUN	WELD PROCESS	SIZE OF METAL	FILL	CURRENT (A)	VOLTAGE (V)	POLARITY	SPEED Inch/min	HEAT I/P KJ/mm
ROOT	SMAW	3.25mm		60 - 75	23 - 27	DCEN	2 - 3	1.09 - 1.59
H/PASS	SMAW	3.25mm		90 - 110	26 - 32	DCEP	3 - 4	1.38 - 2.08
FILL	SMAW	4.0mm		80 - 110	26 - 30	DCEP	4 - 6	0.82 - 1.30
CAP	SMAW	4.0mm		80 - 110	26 - 30	DCEP	4 - 6	0.82 - 1.30

ELECTRODE DETAILS	
Filler Metal Classification	: E 6010 (ROOT PASS) & E 7018 (ALL PASSES)
Filler metal specification	: SFA 5.1 & 5.5
Trade Name	: ESAB
Baking / Storage	: AS PER MANUFACTURERS RECOMMENDATION
"F" Number	: 3 & 4
"E" Number	: 1
"P" Number	: 1 & 1
Progression	: UP-HILL all passes
Preparation / Interpass Cleaning	: MECHANICAL GRINDING TO BE DONE AT LEAST ON JOINT FACES / MECHANICAL BRUSHING & MANUAL CHIPPING
Fit-up method	: EXTERNAL LINE CLAMPS (TO BE REMOVED UPON 25% COMPLETION OF ROOT BEAD)
Pre-heat Temperature	: MINIMUM OF 21 °C (UPTO 19mm THK). IF TEMP < 21 °C OR WET SURFACE, PRE HEAT TO 50 °C WITH PROPANE TORCH
PWHT	: N/A [Refer ASME IX - QW 407.1]
Max time lapse between Root & Hot pass	: WELDING TO BE CONTINUOUS UP TO COMPLETION OF 3 RUNS & 50% OF THE WALL THICKNESS
Max Interpass Temperature	: 250 °C
Oscillation	: MAX 3 TIMES THE DIA OF ELECTRODE OR 12mm
Diameter Range	: Min. 2-7/8" Dia. and above
Thickness Range	: (2.8mm) TO (16.0mm)
Deposited weld metal thickness range	: Maximum of 6mm for E6010 & Max. Of 10.4mm for E7018

Figure 1 – Sample of Welding Details

3.3 Pipe to Pipe Fit Up

- Lay the two (2) pipes on top of the pipe stand or adjustable support, with each pipe ends aligned near each other using adjustable bolt stopper as shown on Figure 2 below.

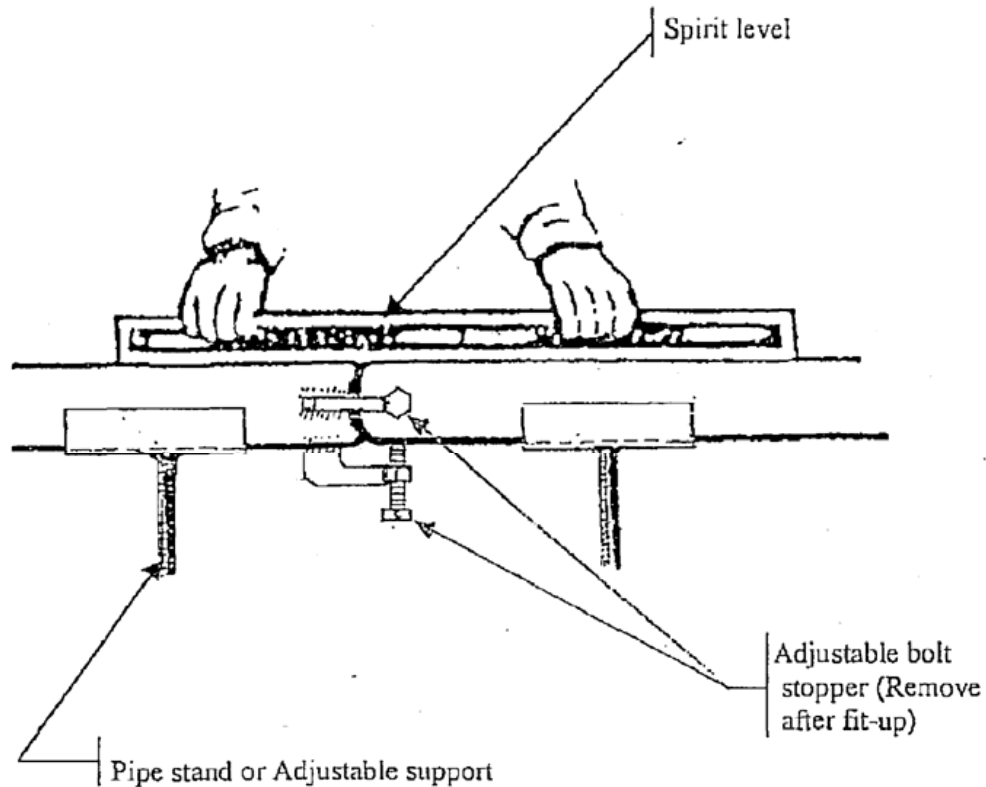

Figure 2 – Pipe to Pipe Fit Up

Note : For larger sizes only, 4" dia. and above

- Level one length of pipe using spirit level.
- Bring lengths together leaving only a small welding gap. In normal practice, a welding electrode of 2.4 mm Ø size, removed of its covering and bent in the middle at an angle of 30° is inserted between the two pipes to obtain a perfect welding gap. It is recommended to weld adjustable bolt stoppers (small piece of plate about 12 mm thick with an M-16 hexagon bolt and nut welded at one end as shown in Figure 2) for perfect and easy alignment.

- Remove the adjustable bolt stoppers after fit up and grind flush all tack welded points making sure that there is no over grinding of the base metal.
- Place the spirit level over both pipes as shown on Figure 2 and maneuver until both pipes are leveled. Adjusting the pipe support can easily do this. Ensure that there is no high-low situation or misalignment between the two outside surfaces.
- Tack weld at the top and bottom.
- Rotate the pipes 90°.
- Repeat the same procedure.

3.4 45° Elbow to Pipe Fit Up

- Lay one (1) pipe on top of the adjustable pipe support.
- Level the pipe using spirit level.
- Place the 45° elbow to the end of the pipe leaving a small welding gap, similar to item 4.3.3 for Pipe to Pipe fit up.
- Place a 45° spirit level on the face of the elbow until bubble is centered and ensure that there is no high-low situation or misalignment between the two outside surfaces.
- Tack weld in place both the pipe and the elbow.

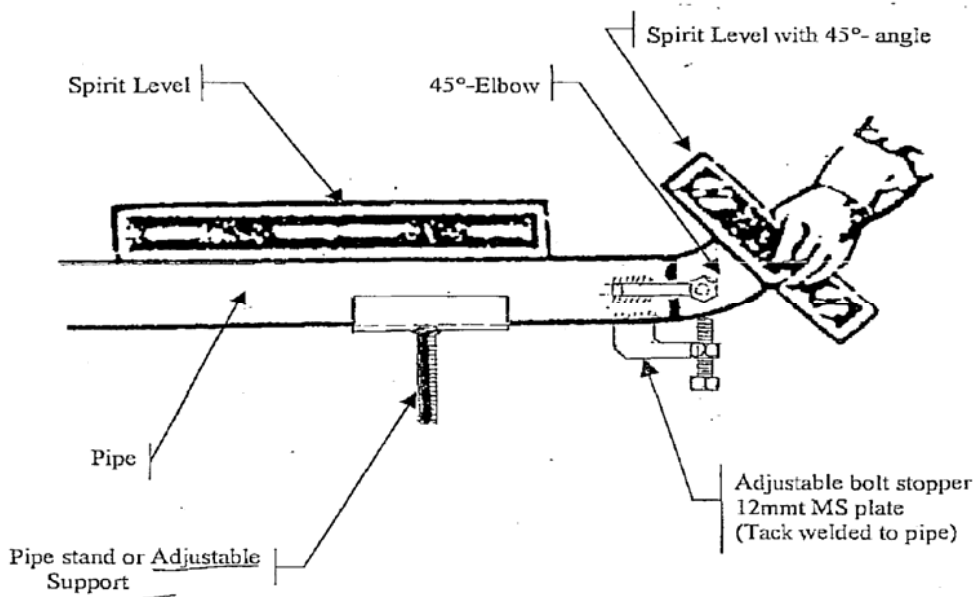

Figure 3 - 45° Elbow to Pipe Fit Up

Note : For larger sizes only, 4" dia. and above

3.5 90° Elbow to Pipe Fit Up

- Lay one (1) pipe on top of the adjustable pipe supports.
- Level the pipe using spirit level.
- Place the 90° elbow to end of the pipe leaving a small welding gap the same as item 4.3.3 for Pipe to Pipe Fit up.
- Place a spirit level on the face of the elbow and maneuver the elbow until it is leveled and ensure that there is no high-low situation or misalignment between the two outside surfaces.
- Tack weld in place both the pipe and elbow.

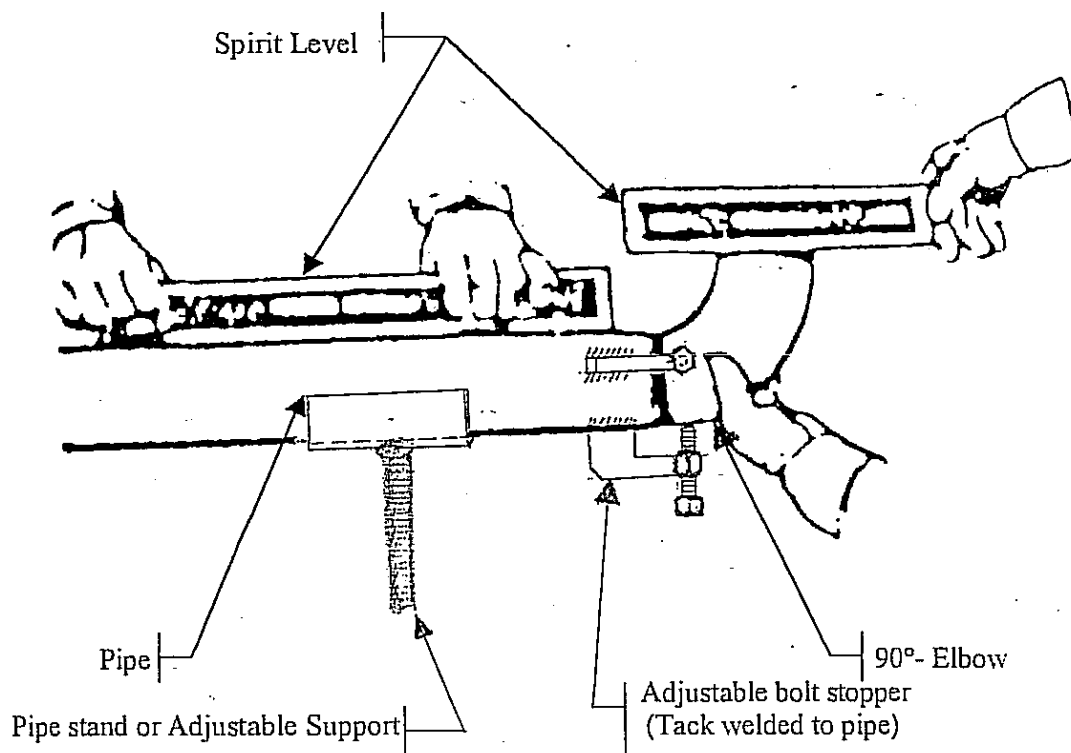

Figure 4 - 90° Elbow to Pipe Fit Up

Note : For larger sizes only, 4" dia. and above

3.6 Tee to Pipe Fit-Up

- Lay one (1) pipe on top of the on the adjustable Pipe supports.
- Level the pipe using spirit level.
- Place the tee at the end of the pipe leaving a small welding gap the same as item 4.3.3 for Pipe to Pipe fit up.
- Place a spirit level on the face of the tee and maneuver the tee until leveled and ensure that there is no high-low situation or misalignment between the two outside surfaces.
- Tack weld in place both the pipe and tee.

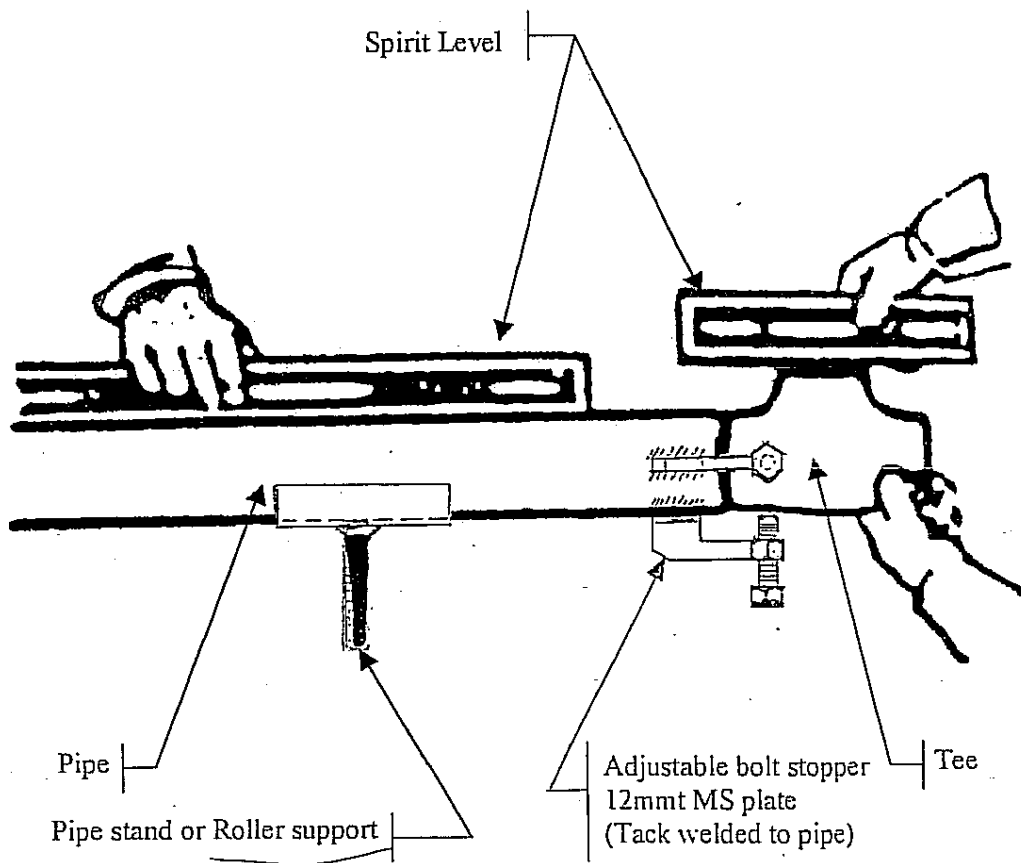

Figure 5 - Tee to Pipe Fit Up

Note : For larger sizes only, 4" dia. and above

3.7 Flange to Pipe Fit-Up

- Lay one (1) pipe on top of the adjustable pipe support.
- Level the pipe using spirit level.
- Bring the flange at the end of the pipe leaving a small welding gap the same as item 4.3.3 for Pipe to Pipe fit-up (In case a Weld neck type of flange is used). If a slip-on type of flange is to be used, insert the pipe to the flange bore up to 5mm depth from the flange face to give enough space for a fillet weld.
- Align the top two (2) holes of the flange with the spirit level.
- Tack weld in place the pipe and flange.

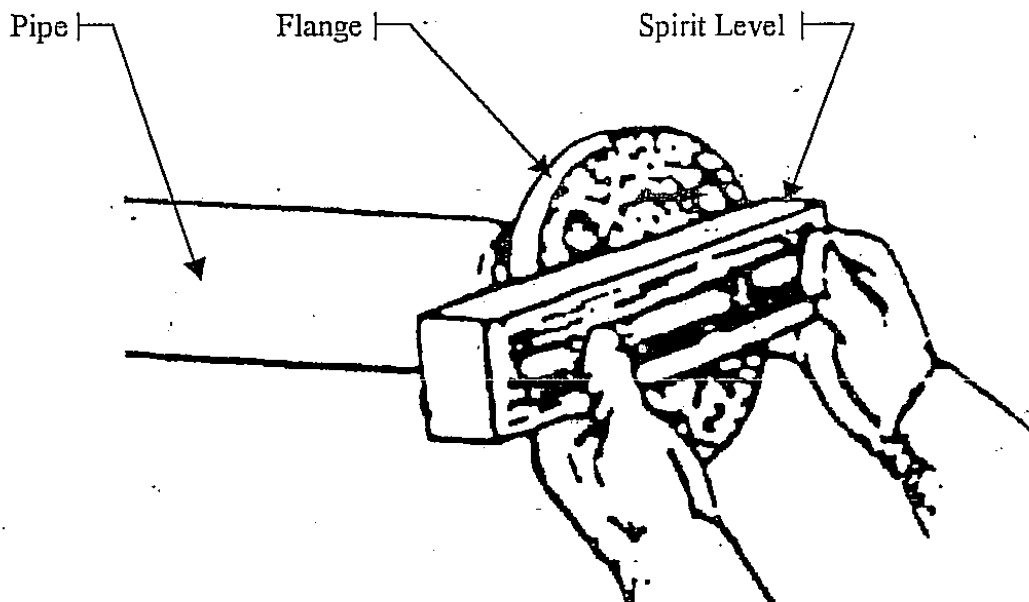
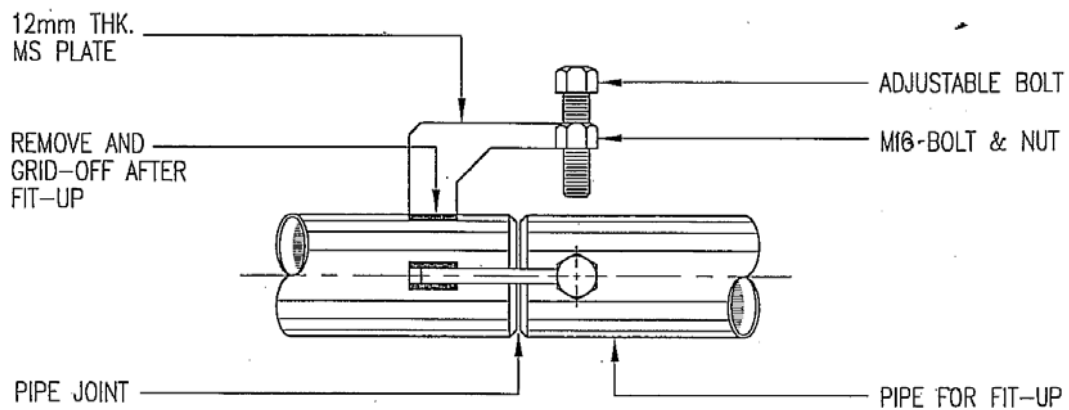
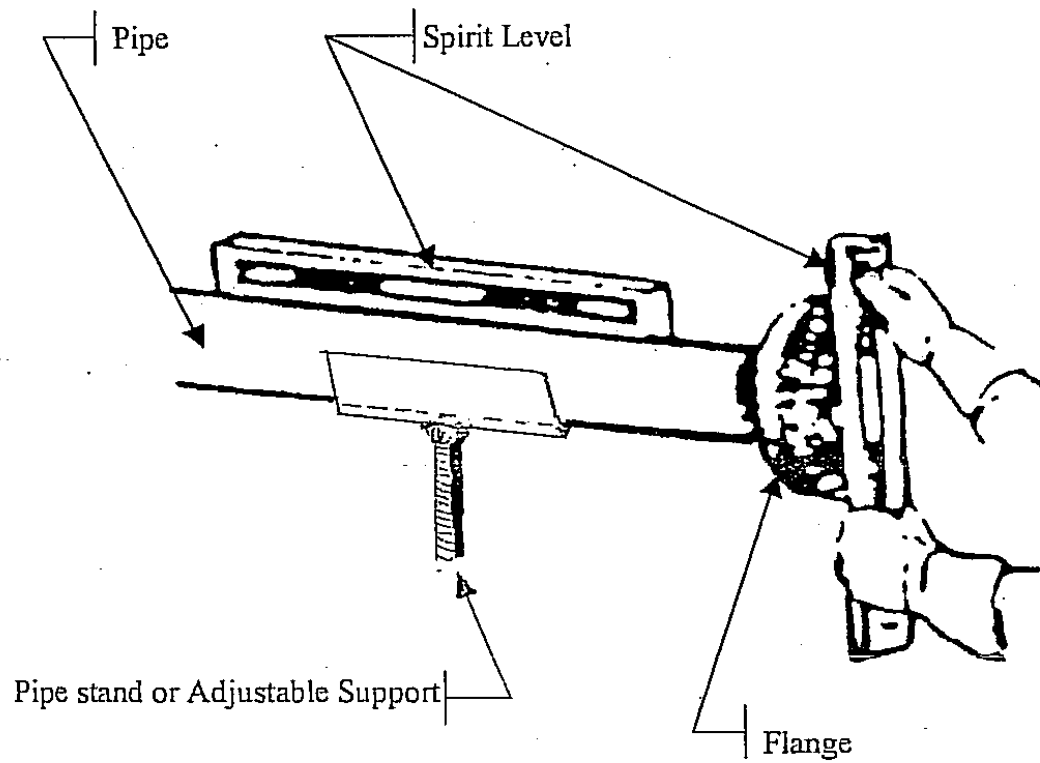

Figure 6 - Flange to Pipe Fit Up



TYPICAL DETAILS OF ADJUSTABLE BOLT STOPPER USE FOR PIPE FIT UP and ALIGNMENT

Note : For larger sizes only, 4" dia. and above

4.0 List of Main Equipment, Tools, Instruments

4.1 EQUIPMENT AND TOOLS

- A. Boom truck
- B. Chain blocks (1Ton – 5Ton Cap.)
- C. A-frame (steel fabricated)
- D. Nylon sling or straps (New and tested)
- E. Set of shackles
- F. Adjustable bolt stopper
- G. Adjustable pipe supports
- H. Spirit level
- I. Alignment Tools (Plumb Bob, Chalk line, Nylon String Line, Felt Tip Marker)
- J. Welding Personnel Protective Equipments
- K. Hand tools
- M. Steel measuring tape
- N. Angle & Straight Grinders
- O. Welding Machines
- P. Steel Scaffolding and Ladders

5.0 Health, Safety and Environment Measures

5.1 Preparation

Notify all concerned in site for the date of material delivery.

- Coordinate with Safety Department for delivery trucks access routes.
- Ensure all workers involved in the hauling operation put on PPE all times.
- Brief individual worker the roles and responsibilities of each.
- Ensure transporter route is cleared of obstruction.
- Coordinate with Construction Department for Pipe Hoisting area.
- Ensure designated hoisting area is cleared of obstruction.
- The lorry transporting the pipes will be guided to the designated hoisting area and released all the latching belts only after the lorry parked firmly.

5.2 Pipe Lifting

- Ensure safe work procedure for lifting operation is observed.
- Ensure proper lifting method - with the correct equipments are used.
- Ensure the pipes are firmly placed on the designated location before releasing the hoisting hook.

5.3 During Site Execution

- Ensure workers are distributed to each designated place.
- Ensure workers at all times to be in proper gear where required.
- Ensure all workers assigned are involved in its particular task.
- Brief individual worker the roles and responsibilities before start work.
- Ensure the pipe lengths to suit site routes into designated work area.
- Ensure pipe support systems are installed accordingly as required.
- Ensure all tools to be used have been inspected and tag by Safety Dept.
- Ensure work areas are clearly marked to restrict access to authorized personnel only.
- Ensure that equipments to be used are properly tagged and checked.
- Ensure that welders are qualified, with the correct PPEs, and well versed on the job at hand with the latest revised drawing/s.

5.4 Housekeeping

- Maintain cleanliness and orderly stocking of materials & tools.
- Pick up and dispose wastes & other debris prior to leaving site area.
- Remove safety yellow tape or other warning devices that were used to control access to the work area.
- Store tools, equipment and unused materials properly at the end of the workday.

5.5 Safety Inspections

- It shall be responsibility of the Supervisor to routinely inspect the physical areas under their control in pipe welding works. This inspection shall include determining if pipes, supports, scaffolds and ladders are appropriately installed and/or use, and if the job site is cleaned up after the day's work.

INSPECTION CHECKLIST FOR WELDING MONITORING

Report No. :.....

Contractor's Name :.....

Description of Works :Pipe Welding.....

Reference No. :

Date Prepared :

Specific Location..... Inspection Requested : Date Time
.....

ITEMS TO BE PERFORMED Accept Reject Hold Remarks

1. WELDING ELECTRODES & CONSUMABLES

- 1.1 Type of Consumables
- 1.2 Type used is per approved submittal (Yes/No)
- 1.3 Storage condition & handling satisfactory

2. WELDING PROCEDURE MONITORING

- 2.1 Type of Joint
- 2.2 Joint Alignment
- 2.3 Chamfer uniform & free of ripples or notches
- 2.4 Root Face (height per approved WPS)
- 2.5 Tack welds
- 2.6 Root gap and free from foreign matter
- 2.7 Interpass cleaning & slag removal
- 2.8 Root Pass inspection
- 2.9 Interpass temperature
- 2.10 Electrical requirements
- 2.11 Welding speed & number of passes
- 2.12 Welding Process (**SMAW/GTAW/SAW/GMAW**)

3. VISUAL INSPECTION

- 3.1 Welder stamp identified (Hard Stamped)
- 3.2 Joint Number
- 3.3 Welds acceptability per code
- 3.4 Width & height of capping pass acceptable

Observations :

Signature

Name

Date